



**GB** **Operator's manual:** It is the owner's responsibility to ensure that all operators of this machine have read and understand the content of this manual before using the product! Careless or improper use of this machine can cause serious or even fatal injury! Allow only competent adults to operate this machine!

**FS 3800**  
**FS 6500**



---

## CONTACT INFORMATION

---



### **Construction Products, North America**

#### **Corporate Office**

17400 West 119th Street, Olathe, Kansas 66061 USA

Corporate Office: 913-928-1000

Corp. Office Fax: 913-438-7951

**[www.husqvarnacp.com](http://www.husqvarnacp.com)**

For local service, please contact your local Husqvarna Construction Products representative.

Para efectuar un servicio local, póngase en contacto con su representante local de Husqvarna Construction Products.

Pour toute réparation, contacter le représentant local de Husqvarna Construction Products.

Für Service vor Ort wenden Sie sich bitte an Ihren örtlichen Vertreter von Husqvarna Construction Products.

Neem voor plaatselijke service contact op met uw plaatselijke vertegenwoordiger van de constructieproducten van Husqvarna.

Per assistenza, rivolgersi al rappresentante di zona della Husqvarna Construction Products.

För service på platsen, kontakta din lokala representant för Husqvarna Construction Products.

Para obter serviço técnico local, contactar o representante da Husqvarna Construction Products

### **Europa / Europe:**

#### **Husqvarna Construction Products**

SE-433 81 Partille, Sweden

Tel: +46 31 94 90 00

Fax: +46 31 94 90 50

### **Asia Pacific:**

#### **Husqvarna Construction Products, Australia Pty Ltd**

25-31 Kinkaid Avenue,  
North Plympton, Adelaide,  
South Australia 5037

Tel: +61 (0)8 8375 1000

Fax: +61 (0)8 8371 0990

### **The Americas:**

#### **Husqvarna Construction Products, North America**

17400 West 119th Street, Olathe, Kansas 66061 USA

Toll-Free Telephone: 800-288-5040, Telephone: 913-928-1300

Fax: 913-438-7938



EVERY MACHINE IS THOROUGHLY TESTED BEFORE LEAVING THE FACTORY. EACH MACHINE IS SUPPLIED WITH A COPY OF THIS MANUAL. OPERATORS OF THIS EQUIPMENT MUST READ AND BE FAMILIAR WITH THE SAFETY WARNINGS. FAILURE TO OBEY WARNINGS MAY RESULT IN INJURY OR DEATH. FOLLOW INSTRUCTIONS STRICTLY TO ENSURE LONG SERVICE IN NORMAL OPERATION.

## Table of Contents

<b>CONTENTS</b>	<b>PAGE NO.</b>
Contact Information	2
Symbol Definitions	4-5
Decal Locations	6-7
Safety Warnings – DO's and DO NOT's	8-9
Blade and Engine RPM	10-11
WARNINGS – Hearing and Dust	12
Saw Controls Diagram	13
<b>OPERATION INSTRUCTIONS</b>	
1. Uses	14
2. Assembly	14
3. Check Before Operating	14-15
4. Operating Instructions	15-16
5. Incidents During Operation	16
6. Maintenance	16
7. Accessories	16
8. Repairs	16
9. Spare Parts	16
10. Engine Governor Settings	16-17
Wiring Schematic	18
Raise & Lower Electric Schematic	19
Maintenance Schedule – Saw and Engine	20
Pre-Operation Checklist	21



## SYMBOL DEFINITIONS DEFINICIÓN DE SIMBOLOS

---



- Please read the instructions for use prior to operating the machine for the first time.
- Antes de la puesta en marcha, lea detenidamente las instrucciones y familiarícese con la máquina.



- Mandatory
- Obligatorio



- Indication
- Indicación



- Prohibition
- Prohibición



- Warning Triangle
- Triángulo De Advertencia



- Wear Eye Protection
- Usar Gafas De Protección



- Wear Head Protection
- Usar Casco De Protección



- Wear Breathing Protection
- Usar Máscara De Protección



- The Use Of Ear Protection Is Mandatory
- Es Obligatorio El Uso De Protección Auditiva



- Wear Safety Shoes
- Usar Zapatos De Seguridad



- Wear Appropriate Clothing
- Usar Ropa Adecuada



- Motor Off
- Parar El Motor



- Use In Well Ventilated Area
- Usar En Una Área Bien Ventilada



- Do Not Use In Flammable Areas
- No Usar In Áreas Inflamables



- Machinery Hazard, Keep Hands And Feet Clear.
- Máquina Peligrosa - Mantenga Manos Y Pies Alejados De La Máquina



- Danger, Poison Exhaust Gas
- Peligro, Gases De Escape Tóxicos



- No Non-working Personnel In Area
- Prohibido Para Personas Ajenas A La Obra



- No Smoking
- No Fumar



- Do Not Operate Without All Guards In Place
- No Operar Sin Todas Las Protecciones In Su Sitio



- Always Keep the Blade Guards In Place
- Mantenga Siempre Las Protecciones De La Hoja En Su Sitio



- Keep Work Area Clean/Well Lit, Remove All Safety Hazards
- Mantenga Limpio El Sitio De Trabajo/Bien Iluminado, Elimine Todos Los Riesgos De Seguridad



- Dangerously High Noise Level
- Nivel De Ruido Elevadamente Peligroso



- Pay Extreme Attention To The Care And Protection Of The Machine Before Starting Up
- Ponga Extrema Atención Al Cuidado Y Preparación De La Máquina Antes De Ponerla En Marcha



- Remove Tools From Area and Machine
- Elimine Las Herramientas Del Área Y De La Máquina



- Oil Required
- Necesita Aceite



- Dipstick, Maintain Proper Oil Level
- Varilla De Control, Mantenga El Nivel De Aceite Correcto



- Lubrication Point
- Punto De Lubrication



- Unleaded Fuel Only
- Solamente Combustible Sin Plomo



- Repairs Are To Be Done By An Authorized Dealer Only
- Las Reparaciones Deben Ser Efectuadas Únicamente Por Un Distribuidor Autorizado



- Diamond Blade
- Sierra Diamantada



- Blade Diameter
- Diámetro De La Hoja



- Muffler Hot. May Cause Burns and / or Ignition Of Material. Avoid Contact.
- Silenciador de tubo de escape caliente. Puede causar quemaduras y/o ignición del material. Evite los contactos.

# DECALS & LOCATIONS ETIQUETAS Y SU UBICACIÓN AUTOCOLLANTS ET LEURS EMPLACEMENTS

## ⚠ CAUTION

WHEN BLADE DIAMETER AND GUARD ARE CHANGED, BELT DRIVE AND ENGINE RPM (GOVERNOR SETTING) MUST ALSO BE CHANGED TO MAINTAIN THE PROPER BLADE RPM (SURFACE FEET PER MINUTE).

DO NOT OPERATE SAW WITHOUT ALL GUARDS SECURELY IN PLACE!

FAILURE TO COMPLY COULD RESULT IN SERIOUS PERSONAL INJURY!

**DECAL, BLADE GUARD CAUTION**

LOCATION: BLADE GUARD

P/N 541 20 06-08

## CAUTION!

# KEEP HANDS CLEAR!

**DECAL, CAUTION, KEEP HANDS CLEAR**  
LOCATION: SHAFT GUARD, BELT GUARD,

REAR COWL PANEL  
P/N 539 30 01-60 (3X)



**DECAL, S.M.I. WARNING**  
LOCATION: BLADE GUARD

P/N 541 20 07-22

## SERVICE INFORMATION

AIR CLEANERS MUST BE CLEANED AND SERVICED TWICE DAILY WHEN OPERATING UNDER DUSTY CONDITIONS (DRY SAWING WITH ABRASIVE BLADES). FAILURE TO CLEAN AND/OR REPLACE FILTER ELEMENTS AND PRE-CLEANER WILL RESULT IN DUST INGESTION BY THE ENGINE. DUST INGESTION WILL WEAR OUT CYLINDERS, PISTONS, RINGS AND BEARINGS IN A FEW HOURS TIME AND WILL RESULT IN COSTLY REPAIRS. ALL ENGINE WARRANTIES ARE VOID IF ENGINE HAS INGESTED DUST. PLEASE REFER TO ENGINE MANUAL FOR MAINTENANCE PROCEDURE.

**DECAL, AIR FILTER SERVICE**

LOCATION: AIR CLEANER

P/N 541 20 06-45

**THIS MACHINE IS COVERED BY  
ONE OR MORE OF THE FOLLOWING  
PATENTS 301,479**

**DECAL, PATENT**

LOCATION: FRONT OF COWL

P/N 541 20 07-13

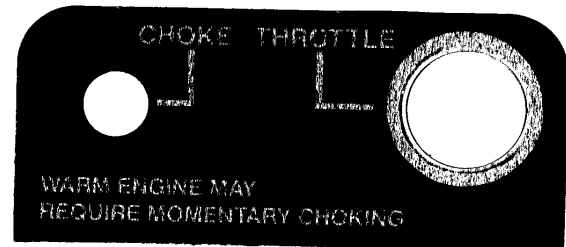

**DECAL, CHOKE / THROTTLE**

LOCATION: THROTTLE BRACKET

P/N 541 20 06-02

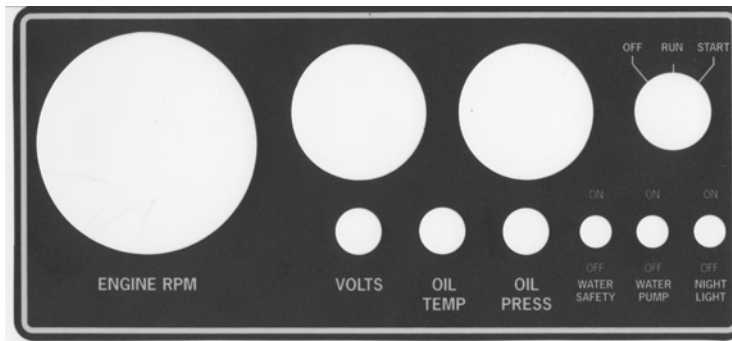

**DECAL, INSTRUMENT PANEL**  
LOCATION: INSTRUMENT PANEL

P/N 541 20 13-25

# DECALS & LOCATIONS ETIQUETAS Y SU UBICACIÓN AUTOCOLLANTS ET LEURS EMPLACEMENTS

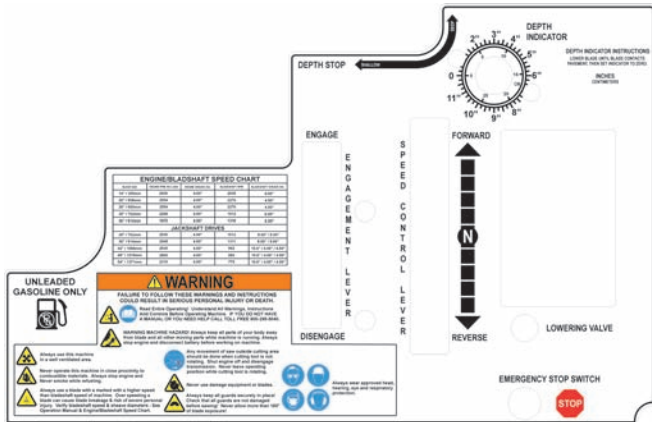

**DECAL, OPERATION INSTRUCTIONS**  
LOCATION: TOP OF COWL  
P/N 502 47 33-01

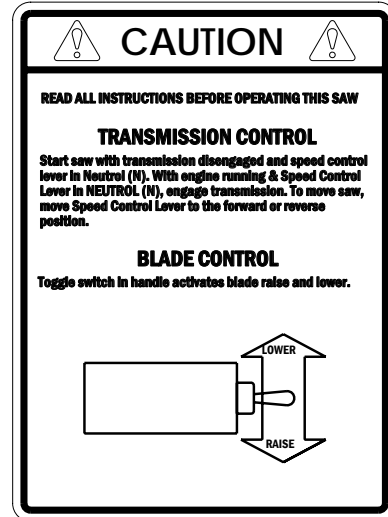

**DECAL, COVER PLATE**  
LOCATION: TOP OF COWL  
P/N 541 20 16-71



## FS 6500

**DECAL, HUSQVARNA FS 6500**  
LOCATION: SIDES OF COWL (2X - FS 6500)  
P/N 542 19 07-04



## FS 3800

**DECAL, HUSQVARNA FS 3800**  
LOCATION: SIDES OF COWL (2X - FS 3800)  
P/N 542 19 07-05



**DECAL, HUSQVARNA, 9.85" LONG**  
LOCATION: REAR OF COWL  
P/N 542 19 07-33

**BEFORE YOU BEGIN:** Read and understand all warnings and instructions before operating the Machine described in this manual. **WARNINGS AND CAUTIONS IN THIS MANUAL MUST BE UNDERSTOOD AND FOLLOWED! FAILURE TO OBEY WARNINGS MAY RESULT IN SERIOUS INJURY OR DEATH. IT IS YOUR RESPONSIBILITY** to make sure persons who use this machine have read this manual.

## **SAFETY WARNINGS FOR OPERATION OF THIS MACHINE**

- DO** read this entire operator's manual before operating this machine. Understand all warnings, instructions, and controls.
- DO** keep all guards in place and in good condition.
- DO** wear safety-approved hearing, eye, head and respiratory protection.
- DO** read and understand all warnings and instructions on the machine.
- DO** read and understand the symbol definitions contained in this manual.
- DO** keep all parts of your body away from the grinding disks and all other moving parts.
- DO** know how to stop the machine quickly in case of emergency.
- DO** shut off the engine and allow it to cool before refueling.
- DO** inspect the accessory disk, and tool adapters for damage before installing the tools.
- DO** use only tools manufactured for use on surface grinders.
- DO** verify grinder drive configuration by checking engine / motor RPM, and spindle shaft RPM, pulley diameters.
- DO** read all safety materials and instructions that accompany any tool used with this machine.
- DO** inspect each tool carefully before using it. If there are any signs of damage or unusual wear, **DO NOT USE THE TOOL!**
- DO** mount the tool solidly and firmly.
- DO** make sure the tool and accessory disk are clean and free of dirt and debris before mounting the tool on the saw.
- DO** use the correct tool for the type of work being done. Check with tool manufacturer if you do not know if tool is correct.
- DO** operate this machine only in well ventilated areas.
- DO** instruct bystanders on where to stand while the machine is in operation.
- DO** establish a training program for all operators of this machine.
- DO** clear the work area of unnecessary people. Never allow anyone to stand in near the machine while the engine is running.
- DO** always tie down the machine when transporting.
- DO** use caution and follow instructions when setting up or transporting the machine.
- DO** have all service performed by competent service personnel
- DO** verify that the tool size is compatible with the machine before mounting the tool.
- DO** make sure the fuel caps of the machine and the fuel can are properly tightened before starting the engine. Move fuel can at least 10 feet from machine after fueling.
- DO** clean the machine after each day's use.
- DO** remove adjusting tool and wrenches from machine before turning it on.
- DO** keep the handles dry, clean and free of oil and dirt.
- DO** carefully maintain and clean for better and safer performance. Follow instructions for changing accessories. Inspect tool cords periodically and, if damaged, have repaired by authorized service facility.
- DO** use caution when handling fuel.
- DO** always give a copy of this manual to the equipment user. If you need extra copies, call TOLL FREE 1-800-288-5040.
- DO** Determine the nature and volatility of any material that will come in contact with the grinding action of the tools used by this machine.
- DO** operate the machine only in areas where the material in contact with the grinding tools is known.
- DO** use only non-flammable and proper substances to improve the material removal from the work area.



**BEFORE YOU BEGIN:** Read and understand all warnings and instructions before operating the Machine described in this manual. **WARNINGS AND CAUTIONS IN THIS MANUAL MUST BE UNDERSTOOD AND FOLLOWED! FAILURE TO OBEY WARNINGS MAY RESULT IN SERIOUS INJURY OR DEATH. IT IS YOUR RESPONSIBILITY** to make sure persons who use this machine have read this manual.

## **SAFETY WARNINGS FOR OPERATION OF THIS MACHINE**

- DO NOT** operate this machine unless you have read and understood this operator's manual.
- DO NOT** operate this machine without all guards in place.
- DO NOT** leave this machine unattended while the engine or motor is running.
- DO NOT** work on this machine while the engine or motor is running.
- DO NOT** operate this machine when you are tired or fatigued.
- DO NOT** operate the machine if you are uncertain of how to run the machine.
- DO NOT** use damaged equipment or tool.
- DO NOT** touch or try to stop a moving tool with your hand.
- DO NOT** transport a machine with the tools mounted on the machine.
- DO NOT** use a tool that has been dropped or damaged
- DO NOT** touch the tools immediately after use. These tools require several minutes to cool after operation.
- DO NOT** use damaged or worn accessory disk.
- DO NOT** allow other persons to be near the machine when starting, refueling, or when the machine is in operation.
- DO NOT** operate this machine in an enclosed area unless it is properly vented.
- DO NOT** operate this machine in the vicinity of anything that is flammable. Sparks could cause a fire or an explosion.
- DO NOT** operate this machine while under the influence of drugs or alcohol.
- DO NOT** operate this machine with any of the guards removed.
- DO NOT** operate this machine unless you are specifically trained to do so.
- DO NOT** start operation of the machine until you have a clear work area and secure footing.
- DO NOT** use flammable substances, unsecured loads or people as extra weight. Injury to the operator or other persons could result!
- DO NOT** use flammable, or improper substances to improve the material removal from the work area.
- DO NOT** operate the machine if unknown substances are on or near the work area.
- DO NOT** operate the machine before you determine the nature and volatility of any material that will come in contact with the grinding tools used by this machine.

\*\*\*\*\*

This machine was designed for certain applications only. DO NOT modify this machine or use for any application other than for which is it was designed. If you have any questions relative to its application, DO NOT use the machine until you have written HUSQVARNA CONSTRUCTION PRODUCTS and we have advised you.

**HUSQVARNA CONSTRUCTION PRODUCTS**  
17400 West 119<sup>th</sup> Street  
Olathe, Kansas 66061, USA

## Blade / Engine (RPM)



### WARNING:

**Important safety information for the operation of pavement saws:**  
**FAILURE TO COMPLY CAN RESULT IN SERIOUS PERSONAL INJURY**

When blade diameter is changed, blade guard, bladeshaft drive and engine RPM (governor setting) **MUST** also be changed to maintain proper blade speed. Bladeshaft RPM must be checked prior to installing blade on equipment (\*3). Proper blade speed (RPM) is very important for safe operation and product performance. The chart, shown below, provides the recommended bladeshaft RPM settings, which will result in proper speeds for various size blades.

<b>FS3800</b>								
<b>BLADE / ENGINE RPM CHART</b>								
Blade Size in Inches	Blade Shaft RPM No Load (*1,*3,*4)	Engine RPM No Load (*1)	Setting Hole No (*2)	Engine Sheave Part No.	Bladeshaft Sheave Part No. (*5)	V-Belts 4-Band (2 Req'd)	Outer Collar (*6)	Inner Collar
12	2869	2550	11	<b>541202083</b> 6G4.5x1.75	<b>541202081</b> 6G4.0x1.75	<b>541200848</b> (3/3VX530)	<b>539300026</b> (4-1/2" Dia)	<b>539300025</b> (4-1/2" Dia)
14	2869	2550	11	"	"	"	"	"
18	2267	2550	11	<b>541202081</b> 6G4.0x1.75	<b>541202083</b> 6G4.5x1.75	"	"	"
20	2267	2550	11	"	"	"	"	"
24	2267	2550	11	"	"	"	"	"
26	2267	2550	11	"	"	"	"	"
30 (*5)	1512	2268	9	"	<b>541201390</b> 6G6.0x(*5)	<b>541201391</b> (3/3VX560 )	<b>541202080</b> (6" Dia)	<b>541202078</b> (6" Dia)
36 (*5)	1316	1975	7	"	"	"	"	"

- (\*1) NOTE: No load speed; machine at full throttle with no blade installed.
- (\*2) NOTE: Governor Setting on Engine. See Engine Governor Settings Section 10, page 14.
- (\*3) NOTE: RPM should be checked under no load conditions at the bladeshaft. A hand held tachometer is best for this purpose.
- (\*4) NOTE: To achieve proper bladeshaft RPM it is necessary to change engine and bladeshaft sheaves along with changing engine governor setting.
- (\*5) NOTE: 541200879 Sheave requires 541202553 Bushing 1.75 SF.
- (\*6) NOTE: All Collars use the 539300010 Dowel Pin, 3/8" Dia x 1-3/4"

# FS 6500

## BLADE / ENGINE RPM CHART

Blade Size in Inches	Blade Shaft RPM No Load (*1,*3,*4)	Engine RPM No Load (*1)	Setting Hole No (*2)	Engine Sheave Part No.	Bladeshaft Sheave Part No. (*5)	V-Belts 4-Band (2 Req'd)	Outer Collar (*6)	Inner Collar
12	2935	2935	10	<b>541202902</b> 8G4.0x2.0	<b>541202906</b> 8G4.0x1.75	<b>541203835</b> (4/3VX530)	<b>539300026</b> (4-1/2" Dia)	<b>539300025</b> (4-1/2" Dia)
14	2935	2935	10	"	"	"	"	"
18	2270	2554	8	"	<b>541202905</b> 8G4.5x1.75	"	"	"
20	2270	2554	8	"	"	"	"	"
24	2270	2554	8	"	"	"	"	"
26	2270	2554	8	"	"	"	"	"
30 (*5)	1512	2268	7	"	<b>541200879</b> 8G6.0x(*5)	<b>541200847</b> (4/3VX560)	<b>541202080</b> (6" Dia)	<b>541202078</b> (6" Dia)
36 (*5)	1316	1975	5	"	"	"	"	"

(\*1) NOTE: No load speed; machine at full throttle with no blade installed.

(\*2) NOTE: Governor Setting on Engine. See Section 10, page 14.

(\*3) NOTE: RPM should be checked under no load conditions at the bladeshaft. A hand held tachometer is best for this purpose.

(\*4) NOTE: To achieve proper bladeshaft RPM it is necessary to change engine and bladeshaft sheaves along with changing engine governor setting.

(\*5) NOTE: 541200879 Sheave requires 541202553 Bushing 1.75 SK.

(\*6) NOTE: All Collars use the 539300010 Dowel Pin, 3/8" Dia x 1-3/4"



## **WARNING**

### **HEARING HAZARD**

DURING NORMAL USE OF THIS MACHINE, OPERATOR MAY BE EXPOSED TO A NOISE LEVEL EQUAL OR SUPERIOR TO **85 dB (A)**



## **ATENCION**

### **RIESGO DE DAÑO AUDITIVO**

EN CONDICIONES NORMALES DE UTILIZACIÓN, EL OPERADOR DE ESTA MÁQUINA PUEDE ESTAR EXPUESTO A UN NIVEL DE RUIDO IGUAL O SUPERIOR A **85 dB (A)**



## **DUST WARNING**



**Cutting, especially when DRY cutting, generates dust that comes from the material being cut, which frequently contains silica.** Silica is a basic component of sand, quartz, brick clay, granite and numerous other minerals and rocks. Exposure to excessive amount of such dust can cause:

- Respiratory diseases (affecting your ability to breath), including chronic bronchitis, silicosis and pulmonary fibrosis from exposure to silica. These diseases may be fatal;
- Skin irritation and rash; and
- Cancer according to NTP\* and IARC\*

\* National Toxicology Program / International Agency for Research on Cancer

Take precautionary steps

- Avoid inhalation of and skin contact with dust, mist and fumes;
- Wet cut when feasible, to minimize dust;
- Wear and ensure that all bystanders wear appropriate respiratory protection such as dust masks designed to filter out microscopic particles. (See OSHA 29 CFR Part 1910.1200)

### **California Prop 65 Warning:**

Use of this product can cause exposure to materials known to the State of California to cause cancer and/or birth defects or other reproductive harm.





- Mandatory
- Obligatorio



- Prohibition
- Prohibición



- Indication
- Indicación



- Warning Triangle
- Triángulo De Advertencia

These signs will give advice for your safety



**Before leaving our factory every machine is thoroughly tested.**

**Follow our instructions strictly and your machine will give you long service in normal operating conditions.**

### 1. Features

**Use:** Wet sawing of old and new concrete and asphalt.

**Tools:** Diamond blades — water cooled, Ø: 12", 14", 18", 20", 24", 26", 30", 36" with Arbor Ø - 1".

*(For information contact your Dealer)*

**Depth of Cut (Maximum):**

Maximum Cutting Depth					
Blade Diameter	12"	14"	18"	20"	24"
Maximum Cutting Depth	3.5"	4.5"	6.5"	7.5"	9.5"

Maximum Cutting Depth					
Blade Diameter	26"	30"	36"	--	--
Maximum Cutting Depth	10.5"	12"	15"	--	--

**Maximum material Size:** N/A

**Nominal & Operating Weight:** See "Specifications".

**Dimensions & Shaft RPM:** See "Saw Dimensions".



**Before starting up machine make sure you read these instructions and are familiar with the operation of this machine.**



**The working area must be completely clear, well lit and all safety hazards removed (no water or dangerous objects in the vicinity)**



**The operator must wear protective clothing appropriate to the work he is doing.**



**We recommend hearing, respiratory and eye protection.**



**Any persons not involved in the work, should leave the area.**



**Only work of flat horizontal areas. Working on steep slopes or hills could cause the operator to lose control of the machine. This could result in injury or death to the operator or other persons in or near the work area!**



**Use only blades marked with a maximum operating speed greater than the blade shaft speed.**

### 2. Assembly

- When unpacked, this unit is fully assembled, except for installation of the Muffler. For tool installation see Section 4 of this document.

### 3. Check Before Operating

**All Models:**



- Take into account the working conditions from a health and safety point of view.
- For start up refer to the engine, or motor manual.



- Engine Fuel: Check the engine operation manual. Unleaded gasoline is recommended.
- Engine Oil: When the *engine* is in a horizontal position, check that the engine oil level is

correct. Check the oil level frequently to ensure that the level never falls below that specified in the engine operation manual. If the oil level is low, add SAE 10W30, service classification SF or SG oil (for normal conditions) as recommended in the engine operation manual. DO NOT overfill engine with oil!

## 4. Operating Instructions

### Preparing to Saw

1. Perform daily maintenance to saw (see chart).
2. Fuel saw if required. Use good grade of regular gasoline (14).
3. Remove blade guard and mount blade securely on blade shaft. For saws equipped with Magnalock one-piece outer collar blade shaft, insert the outer collar through the blade and into the female inner collar. Make sure the blade collars are clean and free of nicks and burrs on the clamping face. Make sure inner collar is tight on the shaft and drive key is in place. Check the drive pin in the outer collar for damage, loose fit or being bent. Check the blade arbor for gouges, nicks or burrs. **SAW BLADE MUST BE HELD TIGHT AND RUN TRUE** to achieve the proper blade performance.
4. If using wet cutting diamond blades, visually inspect coolant spray tubes for plugged or damaged openings. Clean and repair as necessary. Proper coolant flow is essential to good blade performance.
5. Visually inspect blade guard for cracks, hinge failure or loose mounting. Repair or replace guard if necessary. **DO NOT USE SAW WITHOUT BLADE GUARD SECURELY IN PLACE!**
6. Set line guides.

### To Saw

1. Place water safety switch in the OFF position.
2. Start engine and allow it to warm up at half throttle. Observe proper oil pressure and charging amps.
3. Set "Quick Stick" speed control handle (2) to neutral and engage transmission engagement lever (10).
4. Open throttle (5) to full speed position. Engine governor is factory

set. **DO NOT CHANGE SETTING** unless you have changed the saw blade capacity to accommodate larger or smaller diameter blades.

5. Turn on water to blade (8). Set water safety switch to ON position (leave off if dry cutting). If engine stops, recheck water supply. The water safety switch will automatically shut off the engine if proper water pressure is not supplied.
6. Position saw over cut.
7. Lower blade using toggle switch located in speed control handle (2) (follow instructions on handle). Releasing switch will stop blade from lowering. Stop lowering when blade contacts pavement. With blade touching pavement, set cutting depth indicator (6) to "0", then continue lowering until the desired cutting depth is shown on the cutting depth indicator.
8. To use depth stop control (3) turn handle clockwise until resistance is met. For greater depth, turn handle counter-clockwise, for lesser depth turn the handle clockwise.
9. Move speed control handle (2) forward SLOWLY until proper cutting speed is achieved.

### When Cut is Finished

1. Put speed control handle (2) back to neutral position.
2. Raise blade from cut by using the toggle switch in speed control handle. When switch is released, the raise will stop and hold in place.
3. Once the blade is completely out of the cut, turn off water to blade (8).
4. Close throttle (8) to idle position. Let engine cool down before stopping. **DO NOT STOP ENGINE AT FULL THROTTLE!**

NOTE: All sawing is done with engine at full throttle. Engine governor is factory set to achieve proper blade speeds and engine performance. **DO NOT CHANGE GOVERNOR SETTING** unless you are changing blade capacity (Diameter).

### Straight Line Sawing Adjustment

Your saw is equipped with rear axle adjustment to adjust for blade lead off. The adjustment nut is located at the back of the saw on the lower left frame. To adjust saw, stop saw, stop forward drive, remove blade from cut and stop engine. Loosen rear axle mount bolts on left rear of saw.

If the saw is leading to the right, turn the adjustment nut COUNTER-CLOCKWISE. If the saw is leading to the left, turn the adjustment nut CLOCKWISE. Retighten axle mount bolts securely after making adjustment.

DO NOT FORCE ADJUSTMENT!

### 5. Incidents During Operation



**WARNING:** Before inspecting or performing any maintenance, ALWAYS locate the machine on a level surface with the engine / motor OFF, and the start switch in the OFF position, and the power source disconnected.

### 6. Maintenance



**WARNING:** Before performing any maintenance, ALWAYS locate the machine on a level surface with the engine / motor OFF, and the start switch in the OFF position, and the power source disconnected.



**Change Engine Oil:** Change engine oil after every 50 hours of operation.

#### Engine Oil Type

Under normal operating conditions use SAE 10W30 API service classification SF or SG. See engine operation manual for other recommended oil types.

### 7. Accessories

For information contact your local dealer or call our Toll free Customer Service Telephone number shown on the front cover:

### 8. Repairs

We carry out all repairs in the shortest possible time and at the most economical prices. See front cover for our address and telephone numbers.

### 9. Spare Parts

For a quick supply of spare parts it is essential to quote the data shown on the *Serial Number Plate* fixed to the machine. Make note of this information & the purchase date below, and on the front cover of this document for quick reference:

<b>Model:</b>	<b>Serial No:</b>	<b>Date:</b>
_____	_____	_____

### 10. Engine Governor Settings

#### FS 3800 (37 HP VG4D) Engine Governor Settings

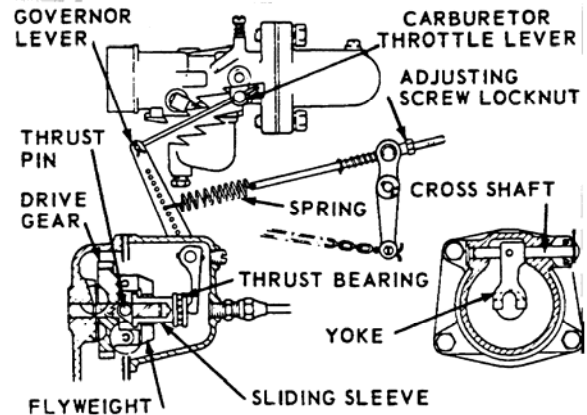
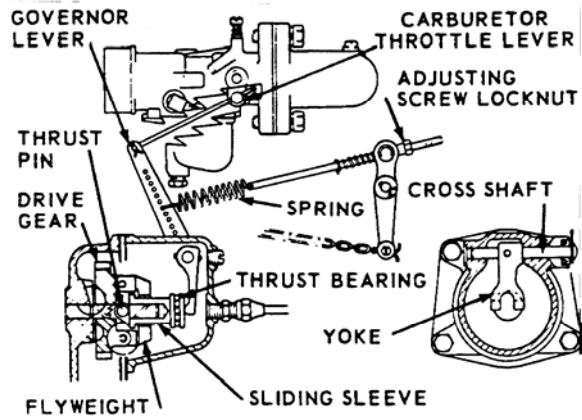

Fig. B

LOAD RPM	NO LOAD RPM	HOLE NUMBER	VG4D Governor Lever Detail
1400	1550	4	
1500	1650	5	
1600	1725	5	
1700	1850	6	
1800	1950	7	
1900	2050	8	
2000	2125	8	
2100	2250	9	
2200	2350	10	
2300	2425	10	
2400	2550	11	



**FS 6500 (65 HP V465D)  
Engine Governor Settings**



**Fig. B**

LOAD RPM	NO LOAD RPM	HOLE NUMBER	V465D Governor Lever Detail
1500	1685	3	<p>HOLE NO.</p> <p>12</p> <p>11</p> <p>10</p> <p>9</p> <p>8</p> <p>7</p> <p>6</p> <p>5</p> <p>4</p> <p>3</p> <p>2</p> <p>1</p>
1600	1825	4	
1700	1855	4	
1800	2000	5	
1900	2055	5	
2000	2200	6	
2100	2230	6	
2200	2375	7	
2300	2440	7	
2400	2545	8	
2500	2695	9	
2600	2745	9	
2700	2810	9	
2800	2935	10	
2900	3065	11	
3000	3175	12	

# FS 3800 & FS 6500 WIRING SCHEMATIC

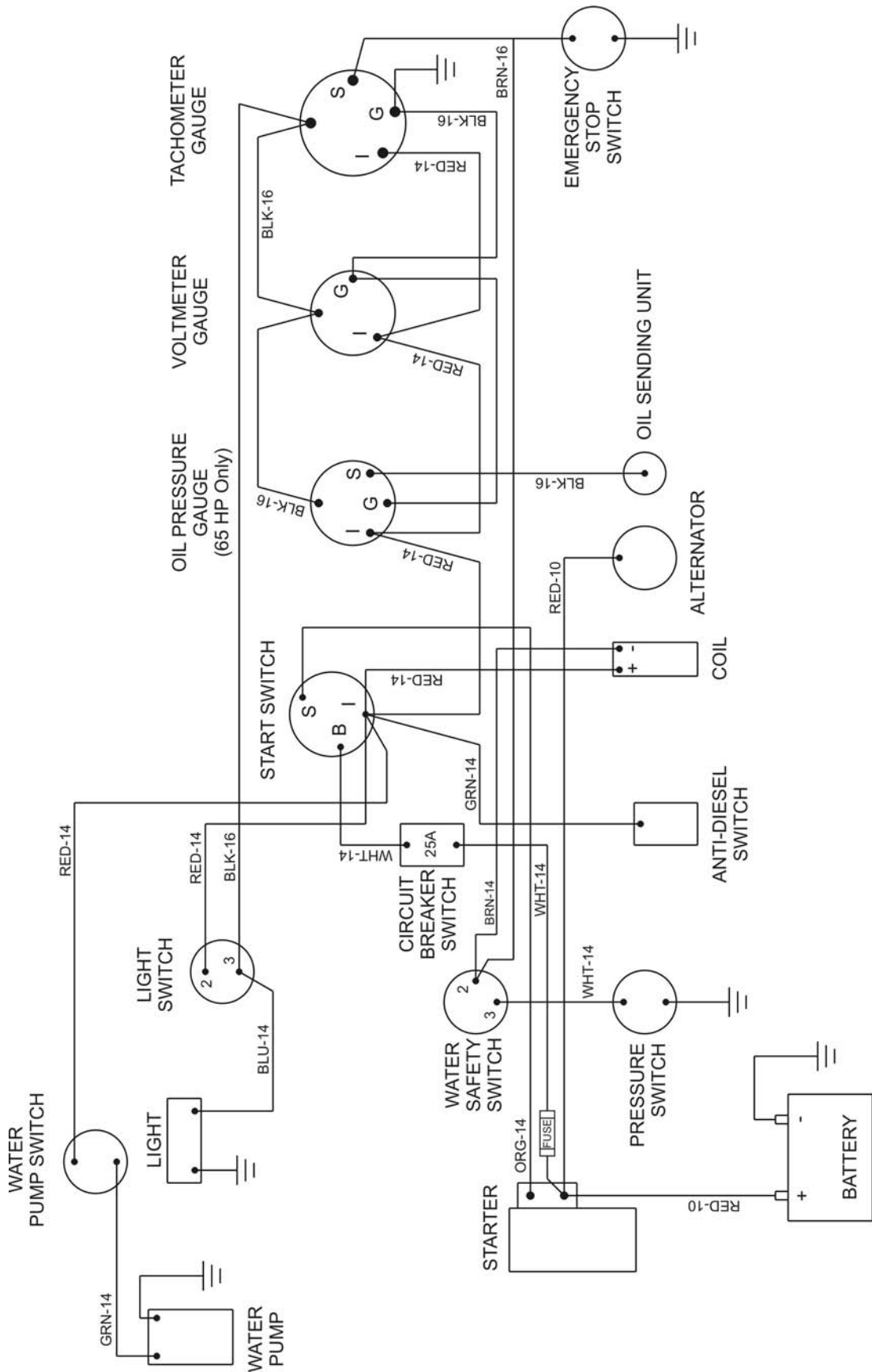

# FS 3800 & FS 6500 Raise & Lower Electric Schematic

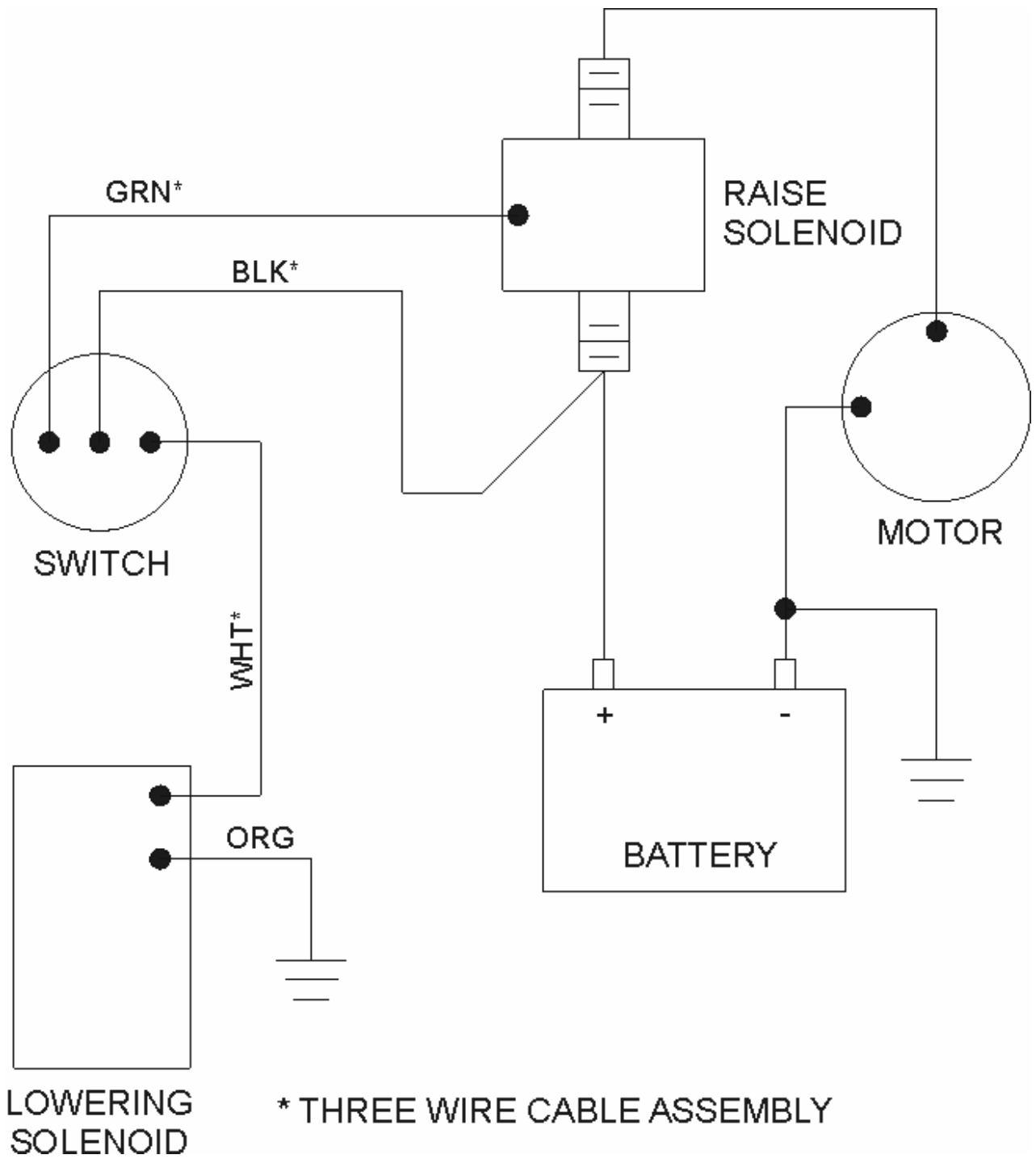

## FS 3800 / FS 6500 SAW & ENGINE MAINTENANCE SCHEDULE

MAINTENANCE PROCEDURE	FREQUENCY			
	DAILY	50 HRS	100 HRS	250 HRS
Check engine oil level, add to full mark. DO NOT OVERFILL!	•			
Check air cleaner. Shake out loose dirt from element.	•			
Check air cleaner connections. Tighten if necessary.	•			
Clean air intake screen. Engine and air cleaner are to be cleaned, too.	•			
Check blade shaft drive belt tension. Replace belts if damaged.	•			
Check transmission drive belt tension. Replace belt if damaged.	•			
Check alternator belt tension. Replace belt if damaged.	•			
Check hydrostatic transmission oil level. Oil should be visible in clear tube.	•			
Grease bladeshaft bearings. DO NOT OVERGREASE!	•			
Check coolant spray tubes in blade guard. Clean if necessary.	•			
Check bladeshaft, bladeshaft bearings, collars and drive pin condition. Bearings should be tight. No free-play side to side, collars should be clean and free of nicks and burrs. Bladeshaft threads should be in good condition and drive pin free of gouges.		•		
Grease front axle, rear axle and bearings.		•		
Change crankcase oil.		•		
Clean crankcase breather cap.		•		
Clean transmission cooling fins.		•		
Replace oil filter with each oil change.			•	
Replace fuel filter.			•	
Check oil level in raise/lower pump.			•	
Replace air cleaner elements.				•
Check and clean battery terminals.				•
Inspect, clean or replace spark plugs and breaker points.				•

**Oil grade/engine capacity chart**  
Use Oils classified as Service MS, SD or SE

SEASON OR TEMPERATURE	GRADE OF OIL	
	FS3800	FS6500
Spring, Summer or Autumn: +120°F to +40°F	SAE 30	SAE 30
Winter: +40°F to +15°F	SAE 20-20W	SAE 20-20W
Winter: +15°F to 0°F,	SAE 10W	SAE 10W
Winter: Below 0°F	SAE SW-20	SAE SW-20
Crankcase Capacity	VG4D 37 HP	V465D 65 HP
New Engine	4-1/2 qts. (4.25 L)	6 qts. (5.67 L)
Oil & Filter Change	5 qts. (4.73 L)	7 qts. (6.62 L)
Less Oil Filter or Filter Change	4-1/2 qts. (4.25 L)	6 qts. (5.67 L)

## PRE-OPERATION CHECKLIST



*Before leaving our factory, every machine is thoroughly tested. Follow our instructions strictly and your machine will give you long service in normal operating conditions.*



*Before starting the machine, make sure that you read this entire Operations Manual and are familiar with the operation of the machine.*

### WITH MACHINE COLD AND SETTING LEVEL:

**Gasoline Models:** Check engine oil. Fill to the full mark on dipstick with 10W30 oil, class MS, SD, SE or better.

### 1-2 HOUR OPERATION CHECK LIST:



***ALWAYS** place the machine on a level surface with the engine / motor “OFF”, the ignition switch set in the “OFF” position and disconnected from the power source before performing any maintenance. Let the machine cool down!!*

1. Check the engine air cleaner hose clamps. Tighten as required.
2. Tension the drive V-belts. DO NOT over tension!

## SCHEDULED MAINTENANCE QUICK REFERENCE



*Before performing any maintenance, **ALWAYS** place the machine on a level surface with the engine / motor “OFF”, the ignition switch set in the “OFF” position and disconnected from the power source!*

### SERVICE DAILY:

1. Check engine oil level.
2. Check all guards for damage.
3. Check hoses and clamps for damage or looseness. Tighten or replace as necessary.
4. Check air cleaner. Clean or replace as required.
5. Clean the machine at the end of the day.

### SERVICE EVERY 50 HOURS:

1. Replace engine oil and oil filter.
2. Clean engine air fins.
3. Check V-belt tension. DO NOT over tension!
4. Clean Engine fuel bowl.





## DUST WARNING



**Cutting, especially when DRY cutting, generates dust that comes from the material being cut, which frequently contains silica.** Silica is a basic component of sand, quartz, brick clay, granite and numerous other minerals and rocks. Exposure to excessive amount of such dust can cause:

- Respiratory diseases (affecting your ability to breath), including chronic bronchitis, silicosis and pulmonary fibrosis from exposure to silica. These diseases may be fatal;
- Skin irritation and rash; and
- Cancer according to NTP\* and IARC\*

\* National Toxicology Program, International Agency for Research on Cancer

Take precautionary steps

- Avoid inhalation of and skin contact with dust, mist and fumes;
- Wet cut when feasible, to minimize dust;
- Wear and ensure that all bystanders wear appropriate respiratory protection such as dust masks designed to filter out microscopic particles. (See OSHA 29 CFR Part 1910.1200)

### **California Prop 65 Warning:**

Use of this product can cause exposure to materials known to the State of California to cause cancer and/or birth defects or other reproductive harm.



[www.husqvarnacp.com](http://www.husqvarnacp.com)

504 63 69-03